

TELESCOPICMAST

NEW

the Compact

The perfect rapid deployment CCTV security solution
when space is limited
and time is of the essence.

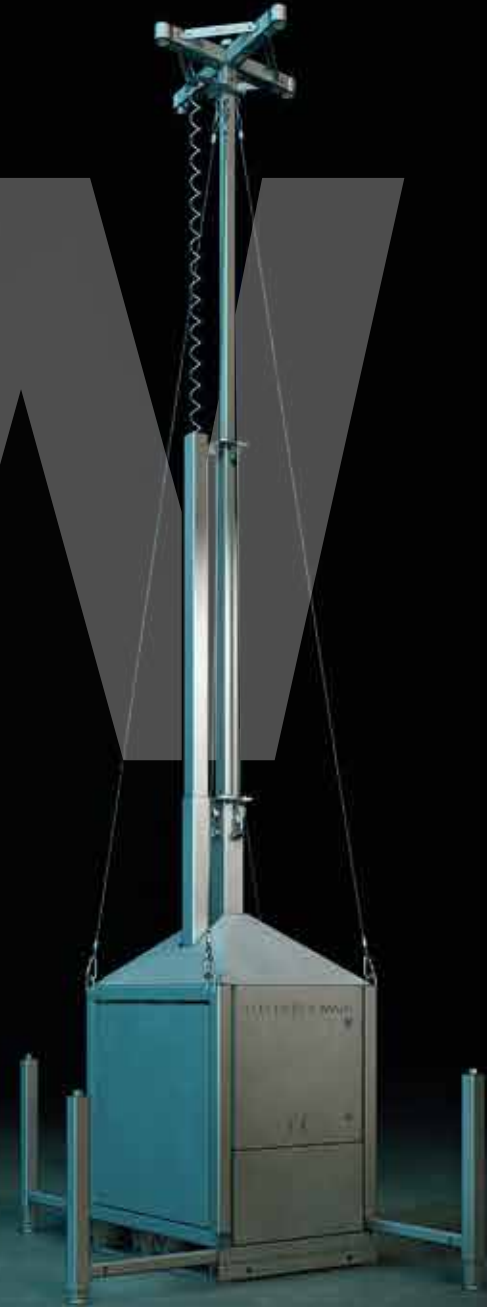

Fast deployment on Temporary Sites!

Faster to deploy and more compact! Compared to its larger brothers, the Basic, Basic Plus, and Premium, the MSB Compact is significantly smaller without having to sacrifice much functionality. However, the smaller size of this mobile security cabinet still offers a lot of advantages. In addition to lower pricing, the size of the cabinet provides for faster deployment and makes indoor use possible.

In addition to faster deployment, the MSB Compact is particularly suitable for locations where space is a limiting factor. For example, in busy urban areas, alongside railway tracks or near roads and busy motorways. Built without compromise its 405cm mast height, will enable you to closely monitor all situations and is suitable for the most common applications in securing terrain, objects, and people.

The MSB compact is above all an easy-to-handle mobile security cabinet. The cabinet has a completely closed housing and comes equipped with an IP66 patch cabinet to make installations quick and easy. The MSB compact is designed to allow you to store all your sensitive equipment inside the cabinet where it is protected from attack or vandalism. There is enough space for additional ballast when the cabinet needs to be able to withstand heavy winds as well as batteries and there is even room for a fuel cell and ancillary equipment in the base.

**Develop your compact mobile security solution now
using the MSB Compact.**



The equipment on the masthead is not included and is shown for reference only

Specifications and Features

MSB COMPACT Specifications

Size LxWxH in feet

2.03x2.62x5.91

Weight in pounds

478

Total height with extended mast (in ft)

13.3

Maximum carrying weight in masttop (in pounds)

132

Certifications

CE CERTIFIED / TÜV pending

Steel galvanised construction

Steel galvanised mast

Basic 3-part telescopic mast 3.15/2.26/1.57 inch

MSB COMPACT Features

Mobile unit easy to transport to site ✓

Easy to store ✓

Basic ground frame ✓

Easy to install by one engineer ✓

Heavy duty forklift slots, for easy transportation ✓

Lifting eyes, for easy transportation and deployment ✓

Stable Telescopic mast with an automatic safety stop ✓

Four spoke masttop for CCTV cameras or floodlight ✓

Spirit level for easy installation ✓

Cylinder lock ✓

Prepared for additional security lock ✓

Fully Lockable cabinet ✓

Vandal resistant cable conduit ✓

Roof climb protection ✓

Patchbox / IP66 box installed ✓

4 stabilizing cables, reducing vibration and false alarms ✓

4 extendable stabilisers to ensure stable mast ✓

Manual CE approved winch 1212 lbs ✓

2 Sides suitable for branding with logo's or messaging ✓

Double cabling in mast (safer for people and equipment) ✓

Sufficient space for installing batteries or fuel cells ✓

Hoisting mast RVS316 stainless steel cables ✓

Hydraulically pressed cable clamp ✓

Manual included ✓

Warning labels ✓



The equipment shown in the picture is for reference only and is not included!

Dimensions and Drawings

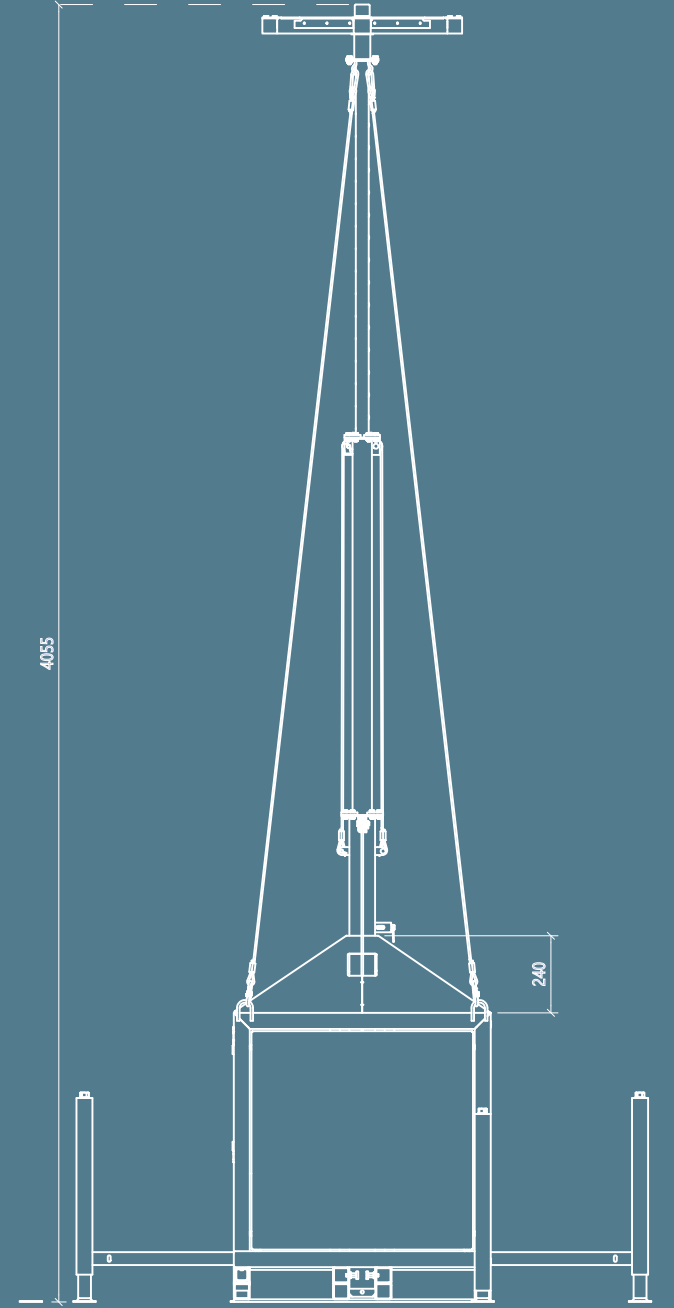
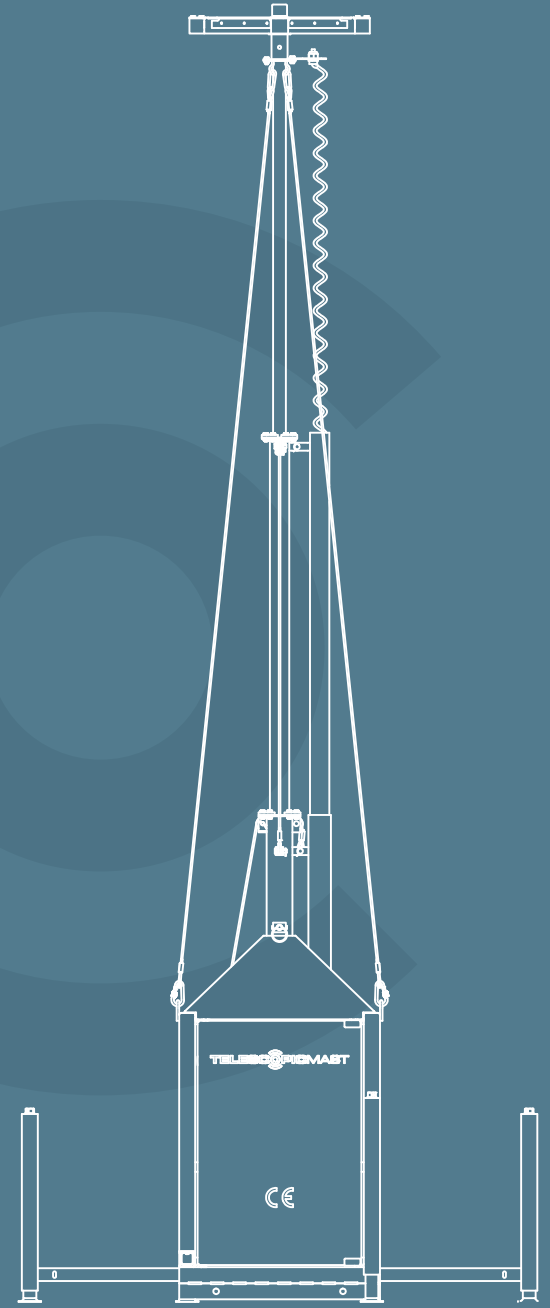
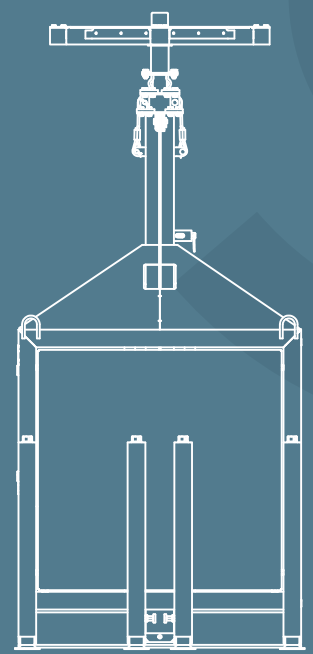
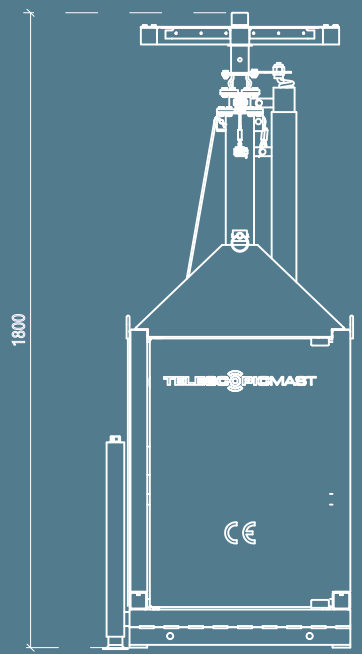

TELESCOPICMAST

1 + 1 = 3

the ROADBOX!

Combine your Compact with the NEW Minitrailer and create the unique 3 in 1 rapid deployment CCTV security solution.



A Flexible highway Hero

The idea for the MSB Compact security cabinet came from our customers, our MSB Roadbox is the logical follow-up. We know that many of our customers use one of our standard trailers to transport our larger cabinets to their desired locations. For this purpose, we designed a special MSB Minitrailer for the MSB Compact and when purchased together you have the MSB Roadbox!

This MSB Roadbox combination, is designed so that the flexibility and rapid deployability of the MSB Compact is fully utilized. Of course, you can still use the Minitrailer to independently transport your fleet of MSB Compacts to various locations or you can deploy the Compact mast on site whilst on the trailer as a stable standalone mast.

Think smart, think Roadbox!



One Solution, multiple Possibilities

You can conveniently leave the Roadbox on location as long as necessary and when you need to redeploy simply retract the legs and attach it to your vehicle. This makes the Roadbox particularly suitable for solving short-term security issues or in situations where the installation needs to be moved regularly.

For example in deployment during emergencies, at events, or temporary roadworks, where the area being protected moves over time. This way, the installation on location becomes much more flexible which saves a lot of installation time, reduces labour costs and speeds up re-deployment times.

This combined mast and trailer solution helps throughout the deployment process and offer greater flexibility on site.

**Build your own Roadbox fleet now
and deploy faster and more flexibly than your competitors.**



The equipment shown in the picture is for reference only and is not included!

The Urban Nomad

The use of temporary CCTV in urban areas requires a different approach. The MSB Basic, Basic Plus, and Premium are protected naturally through their anti-vandalism features and physical height. The MSB Roadbox or the MSB Compact are smaller than their bigger brothers. In the development of these new mast combinations, we have paid a lot of attention to increasing resistance to vandalism.

The MSB Roadbox has been carefully designed to discourage theft and vandalism with a number of security features. The MSB Minitrailer is equipped with a lock and the MSB Compact is secured on the trailer. If you use the MSB Compact freestanding, you can use additional ballast. In combination with the stabilizers, ensuring the cabinet stands firmly on its feet. The control equipment is safely locked inside the cabinet and the wiring to the masthead is protected by a unique and robust steel cable guide system. The cabinet has a sloping top to make climbing difficult.

MSB Compact & Roadbox; Let's protect the city!

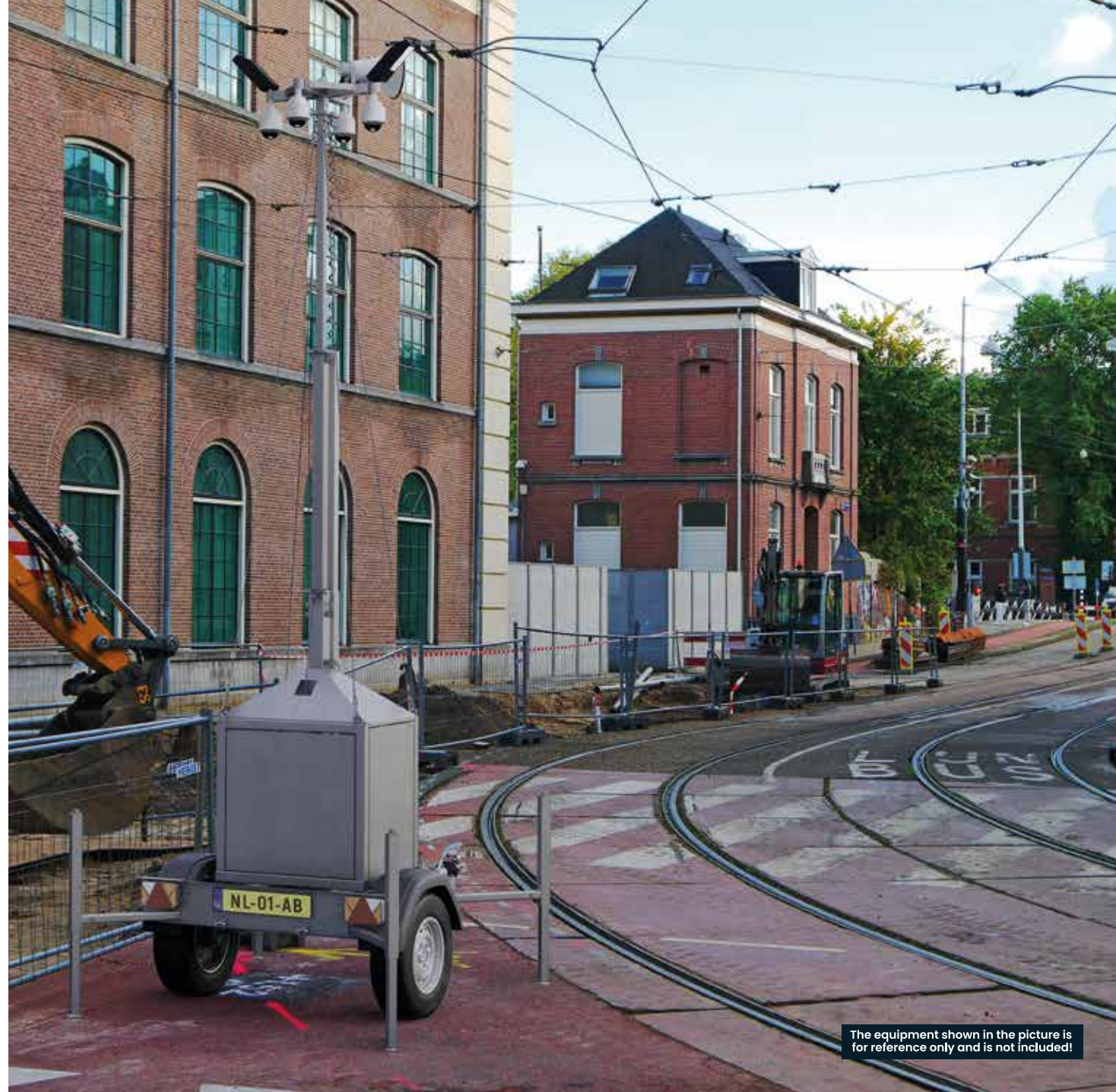

The equipment shown in the picture is for reference only and is not included!

Specifications and Features

MSB ROADBOX Specifications

Size transport mode LxWxH in ft

8.07x4.56x7.48

Size operational mode LxWxH in ft

5.54x4.89x14.86 (drawbar excluded)

Weight in pounds

864

Total height with extended mast (in ft)

14.8

Maximum carrying weight in masttop (in pounds)

132

Certifications

CE CERTIFIED / TÜV pending

Steel galvanised construction

Steel galvanised mast

Basic 3-part telescopic mast 3.15/2.26/1.57 inch

MSB ROADBOX Features

Mobile trailer, unit easy to transport to site ✓

For transport or as a fixed mobile CCTV security solution ✓

Easy to store ✓

Easy to install by one engineer ✓

Heavy duty forklift slots, for easy transportation ✓

Lifting eyes, for easy transportation and deployment ✓

Stable Telescopic mast with an automatic safety stop ✓

Four spoke masttop for CCTV cameras or floodlight ✓

Spirit level for easy installation ✓

Cylinder lock ✓

Prepared for additional security lock ✓

Fully Lockable cabinet ✓

Vandal resistant cable conduit ✓

Roof climb protection ✓

Patchbox / IP66 box installed ✓

4 stabilizing cables, reducing vibration and false alarms ✓

4 extendable stabilisers to ensure stable mast ✓

Manual CE approved winch 1212 lbs. ✓

2 Sides suitable for branding with logo's or messaging ✓

Double cabling in mast (safer for people and equipment) ✓

Sufficient space for installing batteries or fuel cells ✓

Hoisting mast RVS316 stainless steel cables ✓

Hydraulically pressed cable clamp ✓

Manual included ✓

Warning labels ✓



Dimensions and Drawings

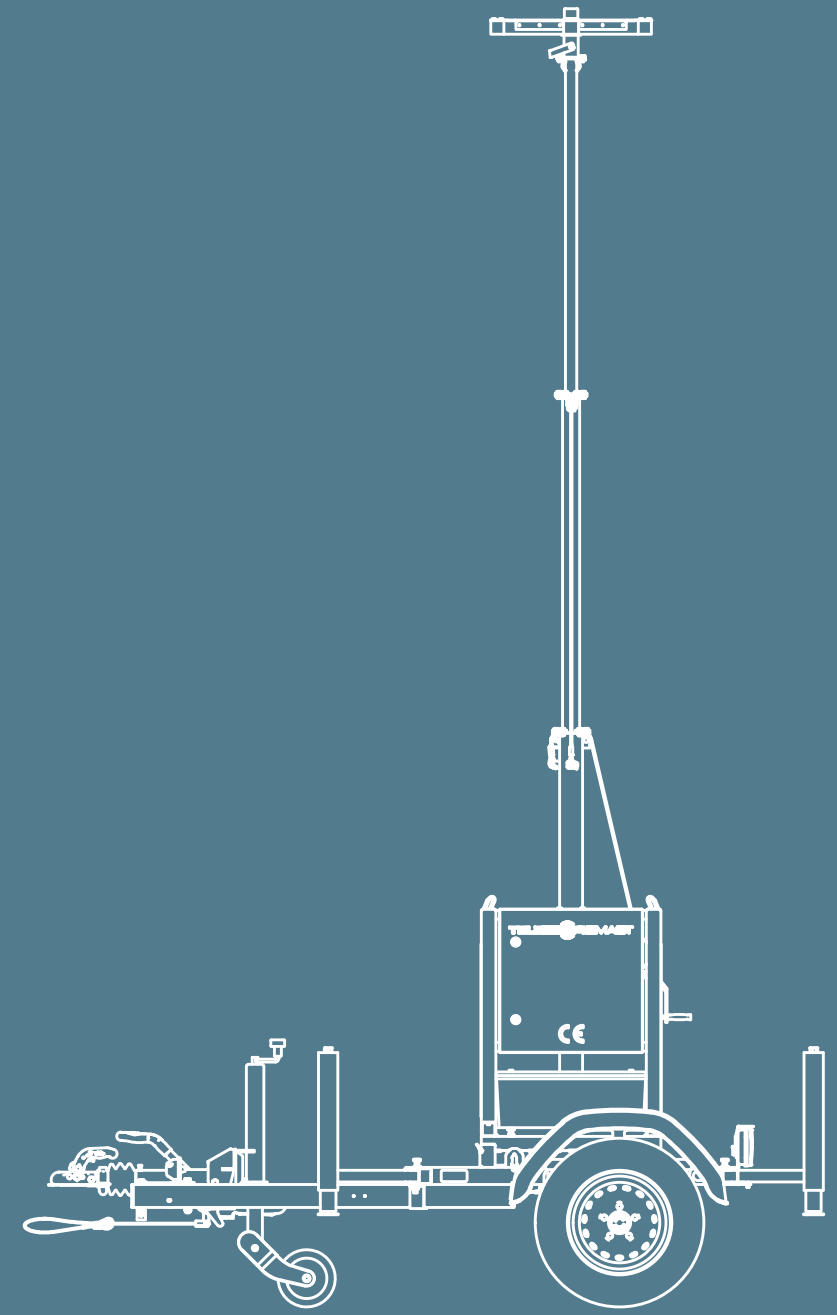
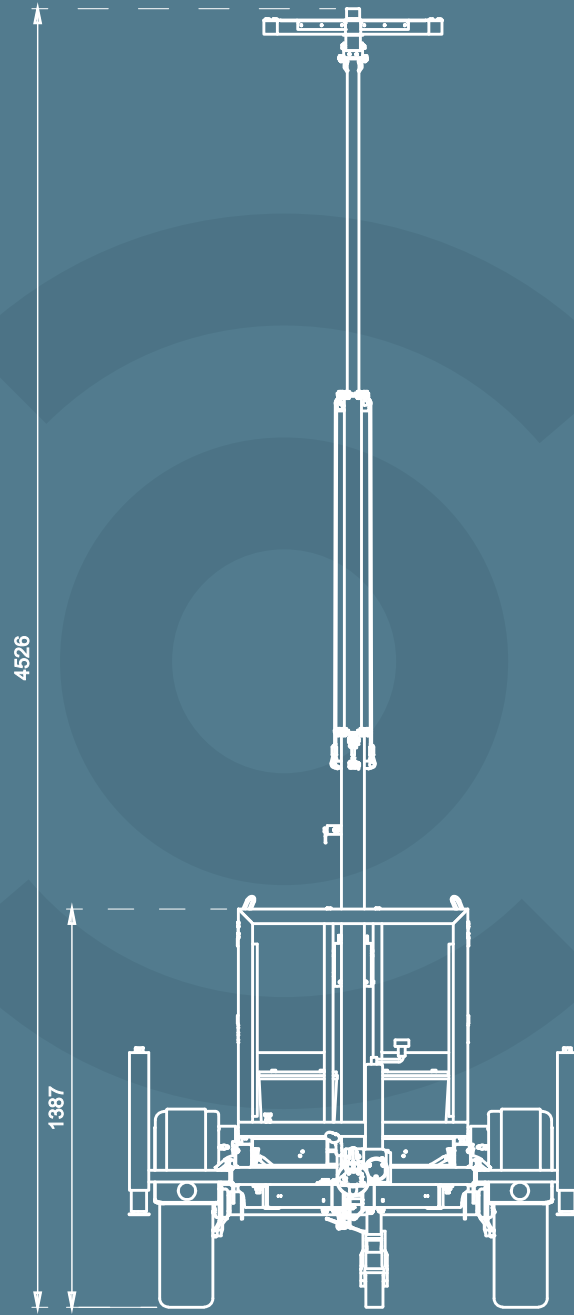
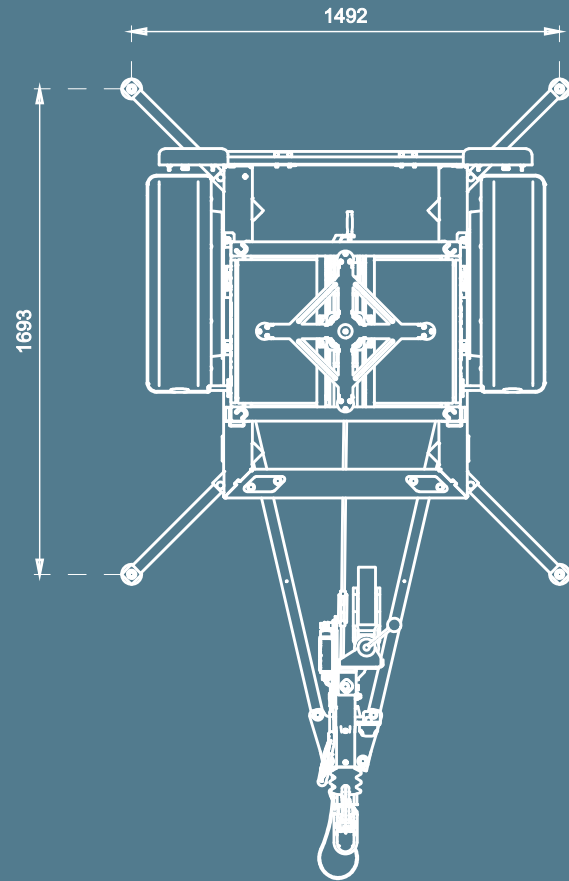

TELESCOPICMAST

the essential Minitrailer

Helping you to quickly and safely deploy
multiple CCTV masts!



Specifications and Features

MSB Minitrailer	Minitrailer Features	
Size LxWxH in ft 8.07x4.56x3.05	Solidly welded and hot-dip galvanized chassis	✓
Weight in pounds 386	Suitable for placing the MSB Compact	✓
Total height (in ft, nosewheel included) 3.05	Screwed drawbar	✓
Total height (in ft, nosewheel excluded) 2.26	Braked overrun brake	✓
Maximum carrying weight (in pounds) 1635	Crash bar	✓
	Breakaway cable	✓
	Axle Knott braked 2976 lbs	✓
	Plug 13-pin	✓
	Lighting according to legal standard	✓
	Off-road wheels 185/70R13	✓
	Socket mounted on stainless steel holder	✓
Certifications CE CERTIFIED / TÜV	Spiral cable with plug-plug 13-pin	✓
	Heavy nose wheel automatically tiltable, static 1102 lbs	✓
	LED-lighting	✓
	Level mounted on chassis	✓
	4x locking pin (for securing the MSB Compact)	✓
	maximum allowable weight 1653 lbs	✓

The MSB Minitrailer is developed for use with the MSB Compact.

The trailer can be used to transport mobile security cabinets to and from sites. When the MSB Compact remains on the Minitrailer it becomes the MSB Roadbox. With both products, you can build a fleet of very flexible and extremely quickly deployable security solutions, standalone or combined!

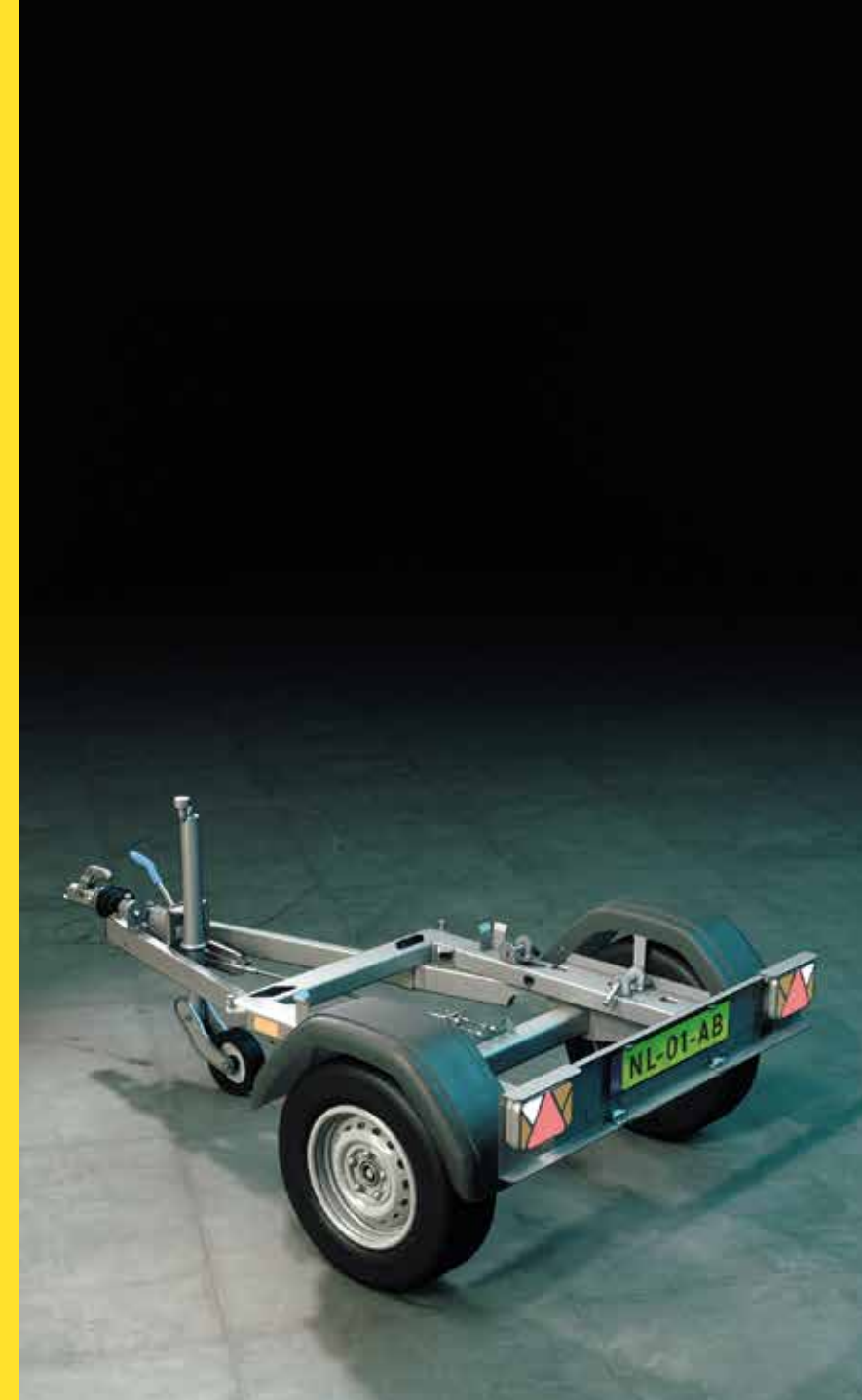

Dimensions and Drawings

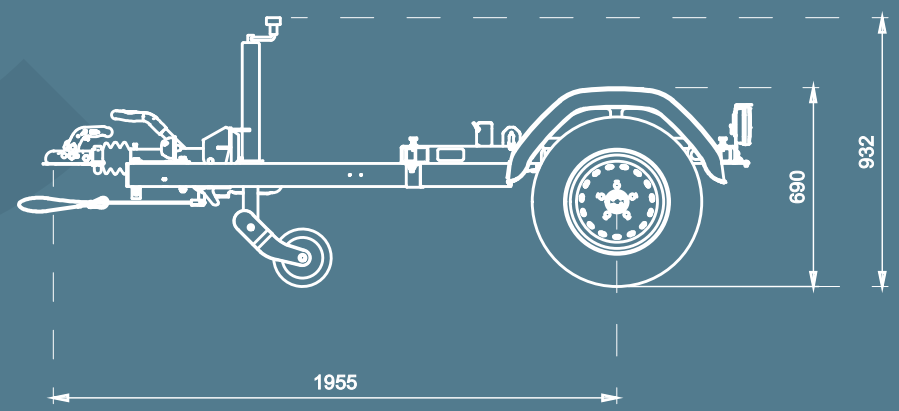
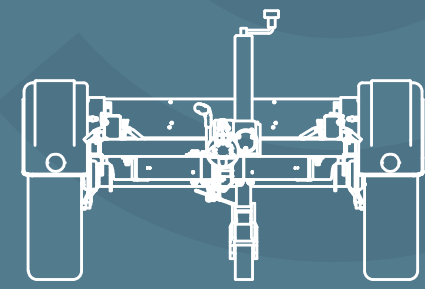
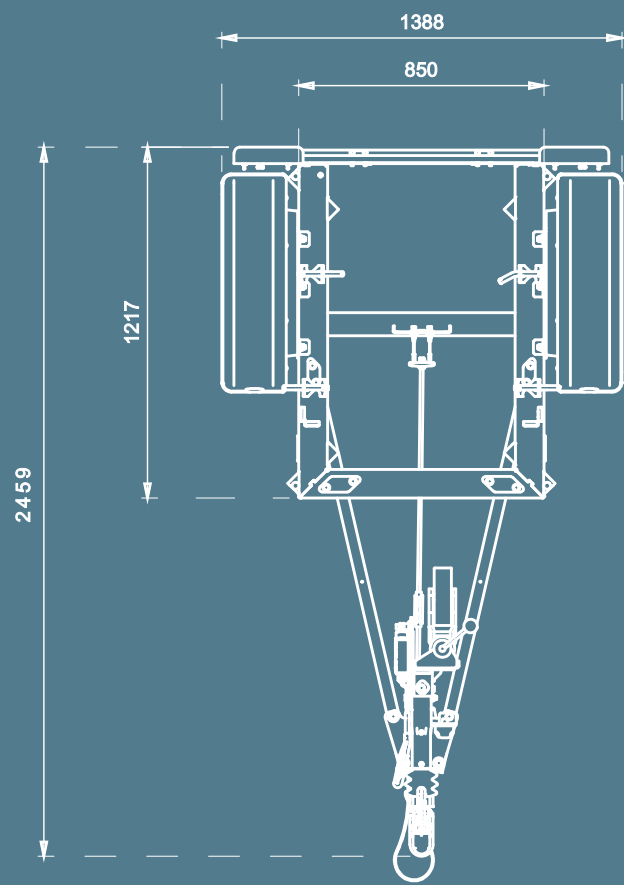

Creating Global site Security



TelescopicMast
Graaf van Solmsweg 101
5222 BS 's-Hertogenbosch,
The Netherlands
phone: + 31 634 185 799

TelescopicMast USA inc.
228 East 45TH Street, Suite 9e
New York, NY 10017
New York, USA

For more information,
please send an e-mail to
sales@telescopicmast.com

Scan the QR code
to watch
our Mobile Security Box in action

